

Worksaver.

*Designed.
Engineered.
Remarkable
Value.*



WORKSAVER®

Models

S-1030 & S-1024 Scoops

Digs, lifts, carries, dumps, and spreads in both directions for greater productivity

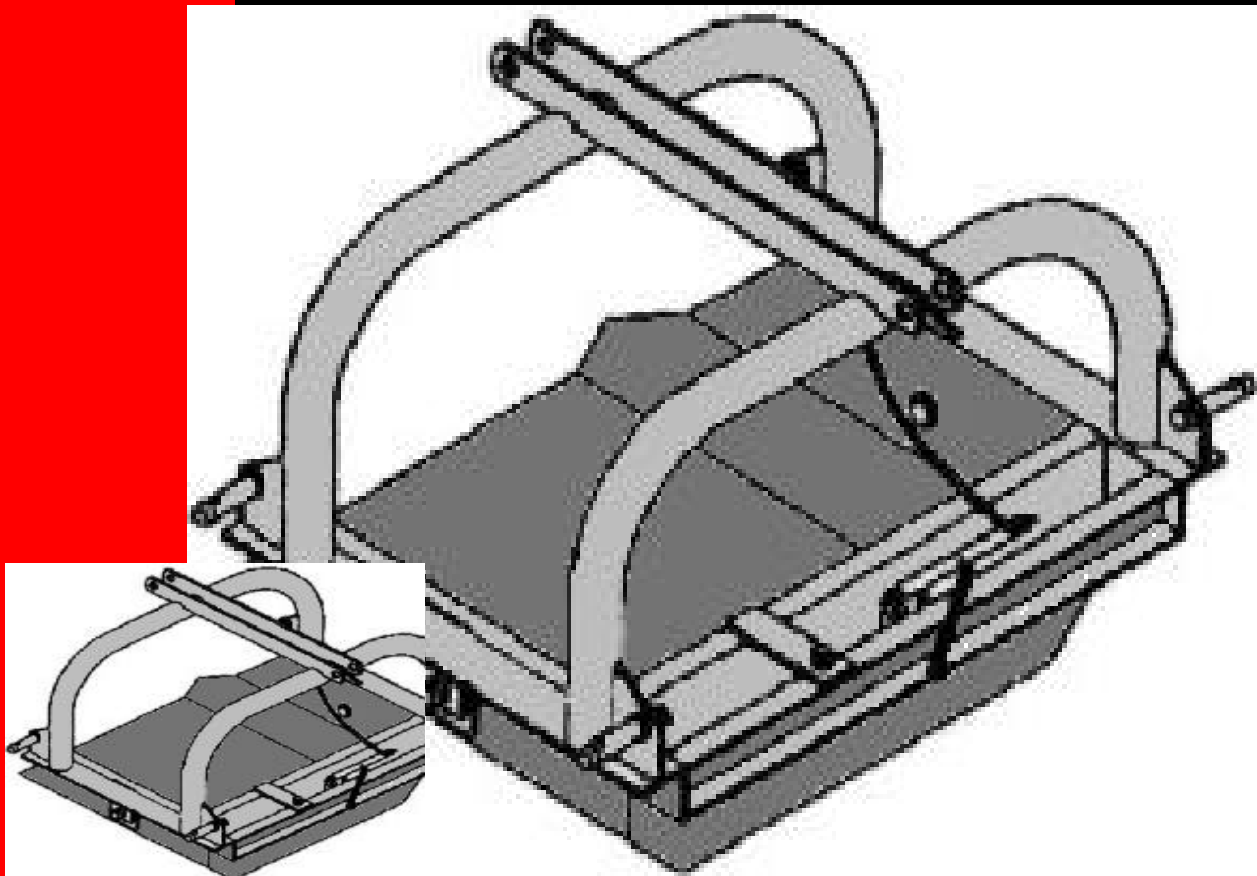

Worksaver

Models S-1030 & S-1024

- Model S-1030 easily mounts on standard Cat. I 3-pt hitch tractors
- Model S-1024 designed for 18hp to 28hp compact tractors with Cat. I and Cat. 0 (7/8" dia pins) 3-pt hitch tractors.
- Scoop is reversible for greater productivity. Forward position works as a pull scraper. Reverse position works as a shovel.
- Digs, lifts, carries, dump and spreads in either position.
- Standard trip rope activates dumping latch from the convenience of the tractor seat.
- Weld-on high carbon steel cutting edge for long life.
- Tractor top link allows easy control of digging angle.
- Extremely economical and efficient. Mounts quickly and needs no special attachments.
- Ten (10) cu./ft. capacity (S-1030)
- Eight (8) cu./ft. capacity (S-1024)

MODEL S-1030 SPECIFICATIONS

Capacity heaped	Ten (10) cu./ft.
Reversible	Yes
Bowl width (in/mm)	30 / (762 mm)
Overall bowl length (in/mm)	31 / (787 mm)
Overall bowl height (in/mm)	11 / (279 mm)
Bowl construction	Welded steel
Bowl thickness	9-gauge steel
Bowl edge	Weld-on high carbon steel
Hitch requirement	Cat. I
Trip rope	Standard
Spring release lock	Standard
Shipping weight (lb/kg)	178 / (81 kg)
Product Computer Number	312000

MODEL S-1024 SPECIFICATIONS

Capacity heaped	Eight (8) cu./ft.
Reversible	Yes
Bowl width (in/mm)	22.5 / (572 mm)
Overall bowl length (in/mm)	25 / (635 mm)
Overall bowl height (in/mm)	10 / (254 mm)
Bowl construction	Welded steel
Bowl thickness	9-gauge steel
Bowl edge	Weld-on high carbon steel
Hitch requirement	Cat. I / Cat. 0 w/ 7/8" pins
Trip rope	Standard
Spring release lock	Standard
Shipping weight (lb/kg)	160 / (73 kg)
Product Computer Number	312015



READ AND UNDERSTAND OPERATOR'S MANUAL BEFORE OPERATION.

Worksaver Inc. has a corporate policy of continuous product improvement and development; therefore, specifications are subject to change without any advance notice. Worksaver Inc. is not responsible for differences between specifications or illustrations contained in this publication and the actual equipment.



Worksaver, Inc.

P.O. Box 100, Litchfield, IL 62056-0100
 Phone: 217-324-5973 • Fax: 217-324-3356

E-mail: sales@worksaver.com

Web: www.worksaver.com

Information Provided By:



Worksaver.

*Designed.
Engineered.
Remarkable
Value.*



Model 580 Mixer

Ideal for mixing feed, fertilizer, inoculating seed, potting soil and other mixing jobs.



Worksaver Model 580 Mixer

- Two piece steel drum construction with internal paddles for uniform mixing and clean dumping.
- Compact, trouble free, long life design with few moving parts.
- Ideal for mixing feed, fertilizer, inoculating seed, potting soil and other mixing jobs.
- Five (5) cu./ft. capacity (1 bag mix).
- Hydraulic top link cylinder provides positive dump control.
- Parking stand for easy storage.
- Number 40-roller chain drives mixing drum.
- Adjustable Cat. I hitch allows easy hook up to most tractors (7/8 Dia. Lift pins).
- Sealed ball bearings provide long service life with reduced maintenance.

Capacity	Five (5) cu./ft. (1 bag mix)
Drum opening (in/mm)	17.5 / (444 mm)
Overall drum length (in/mm)	32 / (812 mm)
Diameter of drum (in/mm)	32 / (812 mm)
Drum construction	2-piece bolted
Drum thickness	11-gauge steel
Cone thickness	14-gauge steel
Drive system	Tractor PTO
PTO driveline	Metric Series I
PTO speed	540 rpm
Drum drive	#40 chain
Drive ratio	8.77:1
Shield PTO drive	Standard
Chain tighter	Standard
Bearing type	Sealed ball bearings
Hydraulic toplink cylinder	Standard (Double Acting)
Cylinder size (in/mm)	1.75 (44 mm) x 13 (330 mm)
Hitch requirement	Cat. I (7/8" Dia. Lift pins)
Hydraulic toplink positions	Three (3)
Lower pull pin positions	Four (4)
Parking stands	Standard
Tractor requirement (min. PTO HP)	25 PTO HP*
Shipping weight (lb./kg)	253 / (115 kg)
Product Computer Number	780620

*Be sure front of tractor is properly counterbalanced w/front-end weights.

**Be sure front of tractor is properly counterbalanced with front-end weights or front-end loader.*

**Designed.
Engineered.
Remarkable
Value.**



READ AND UNDERSTAND OPERATOR'S MANUAL BEFORE OPERATION.



FULL MIXER WILL PUT A HEAVY LOAD ON THE REAR OF YOUR TRACTOR. BE SURE FRONT OF TRACTOR IS PROPERLY COUNTERBALANCED WITH WEIGHTS.



NEVER ALLOW CHILDREN OR BYSTANDERS AROUND TRACTOR OR MIXER WHEN YOU ARE USING EQUIPMENT.

Worksaver Inc. has a corporate policy of continuous product improvement and development; therefore, specifications are subject to change without any advance notice. Worksaver Inc. is not responsible for differences between specifications or illustrations contained in this publication and the actual equipment.



Worksaver, Inc.

P.O. Box 100, Litchfield, IL 62056-0100
Phone: 217-324-5973 • Fax: 217-324-3356
E-mail: sales@worksaver.com
Web: www.worksaver.com

Information Provided By:





WORKSAVER®

9 Worksaver Trail - P. O. Box 100 - Litchfield, Illinois 62056-0100
WEB: <http://www.worksaver.com> E-MAIL: sales@worksaver.com

Quick Hitches (Category II & III)

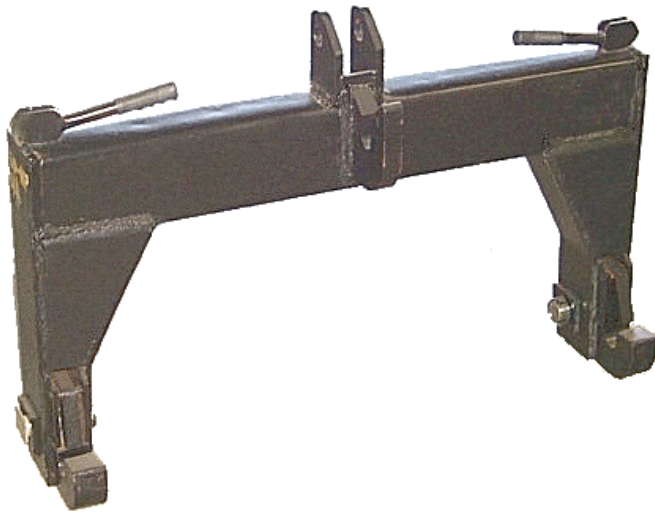

Cat. 2 Quick Hitch

Worksaver Quick Hitches are built for fast, safe, and easy connection (or disconnect) of 3-point implements. It will give you years of trouble-free service in handling your equipment because it is constructed of heavy steel bar and tubing. The Worksaver Quick Hitches fit most Category III 3-point hitch tractors. Completely assembled, ready to mount to your tractor.

Easy, Safe Operation Steps

- ◆ *Back Quick Hitch points to implement mounting pins.*
- ◆ *Raise tractor 3-point hitch until implement draw pins are engaged - if light weight equipment is being used, latch handles may have to be raised to correctly engage implement.*
- ◆ *Implement is connected without a strained back, pinched fingers, or any smashed toes.*
- ◆ *Raised latch handles and reverse procedure to disconnect.*

Quick Hitch Features

1. High strength tubing for torsional strength.
2. Over-center spring-loaded latch mechanism provides positive lock yet easy equipment release.
3. Solid flame-cut parts for long life.
4. beefed-up at known wear points.
5. Non-rotating draw pins and adapter bushings for wear resistance.
6. Tapered top hitch point bracket for easier first time connection.
7. Rubber handle grips on latch handles.
8. Comes completely assembled with hardware.

INFORMATION PROVIDED BY:

Model	Item No.	Description	Lbs.
QH-101	862840	Category I – with adapter (up to 50hp)	76
QH-102	862845	Category II – with adapter (up to 100hp)	134
QH-107HD	862850	Category II HD – with adapter (up to 150hp)	160
QH-103	862855	Category III (up to 225hp)	182
QH-106N	862880	Category III Narrow (up to 225hp)	176
	862500	Cat. I Adapter Bushing Kit	3
	862530	Cat. II Adapter Bushing Kit	2.2





WORKSAVER®

9 WorkSaver Trail - P. O. Box 100 - Litchfield, Illinois 62056-0100
WEB: <http://www.worksaver.com> E-MAIL: sales@worksaver.com

Quick Hitches (Category I)

WorkSaver's QH-101 category 1 quick hitch is adjustable. No tools required.

Pull pin width – Clearance for 26" spacing
Top Link Hook Height – 14.68" to 17.94"

The QH-101 adjustable quick hitch is ruggedly built and rated for tractors up to 50 hp.

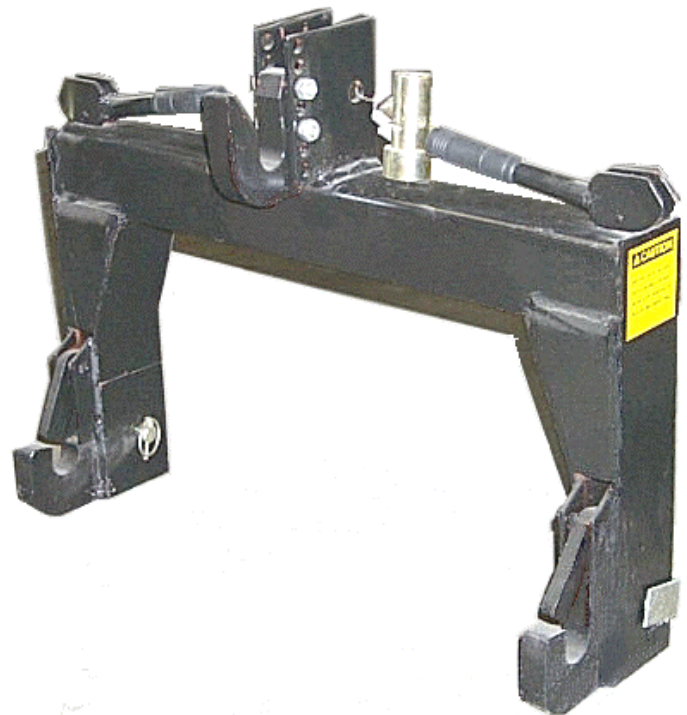

QH-101 Cat. 1 Quick Hitch

Some category 1 equipment has not been built to the exact category 1 ASAE 3-point hitch standard specifications. The top link pin location is too low or high. The QH-101 adjustable quick hitch takes care of most of these problems.

Some 3-point equipment will not accept a top link hook as pictured on the QH-101 quick hitch. The QH-101 provides a special floating top link bracket that allows you to still use the quick hitch to pick up the implement. The floating top link bracket requires manual insertion of pins.

Because Category 1 pins are relatively small and troublesome, expensive to replace, the QH-101 quick hitch is designed to use replaceable wear bushings. One set is included with each quick hitch. Additional bushings may be purchased for other pieces of equipment.

Quick hitches are built for the fast, safe, and easy connection (or disconnection) of 3-point implements. It will give you years of trouble-free service in handling your equipment because it is constructed of heavy steel bar and tubing. The QH-101 quick hitch fits most Cat. I 3-point hitch tractors. Completely assembled, ready to mount on your tractor.