

Worksaver.

Implements
Designed for
Your
Lifestyle.

Worksaver® 3-pt. Hay Spears

SPECIFICATIONS

Model	HS-330	DBH-449
Number of Spears	3	4
Bolt-in Forged Spear Length (in/cm)	26/66 Useable	42/107 Useable
Spear Spacing (in/cm)	28.5/72 On Center	26/66 On Center
Cast Steel Weld-on Socket (Patent Pend.)	Yes	Yes
Number / type of Bales	1 Mid-Size Rectangular Bale	2 Round Bales
Overall Width (in/cm)	60/152	96/244
Hitch Category	Cat.II & III	Cat.II & III
Weight (lb/kg)	163/74	251/114
Product No.	832615	832610

- HS-330 Triple Spear model for handling a mid-size rectangular bale. (spears have useable length of 26")
- DBH-449 Four Spear model for handling two round bales. (spears have useable length of 42")
- Bolt-in forged spears for increased reliability.
- Cast Steel Weld-on Sockets (patent pending) for superior strength.
- Cat.II & III Quick Hitch compatible.



HS-330 – Item #832615



DBH-449 – Item #832610



Worksaver, Inc.

P.O. Box 100, Litchfield, IL 62056-0100
Phone: 217-324-5973 • Fax: 217-324-3356
E-mail: sales@worksaver.com
Web: www.worksaver.com

Information Provided By:



**Implements
Designed
for Your
Lifestyle.**



Bale Handling Equipment

The widest choice of quality hay attachments.



Work saver



**The widest choice
of quality hay attachments.**

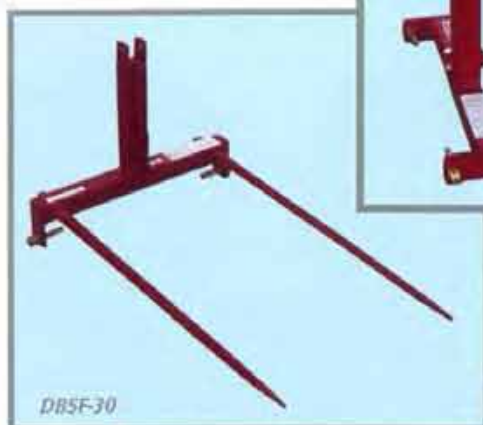

DBSF-30

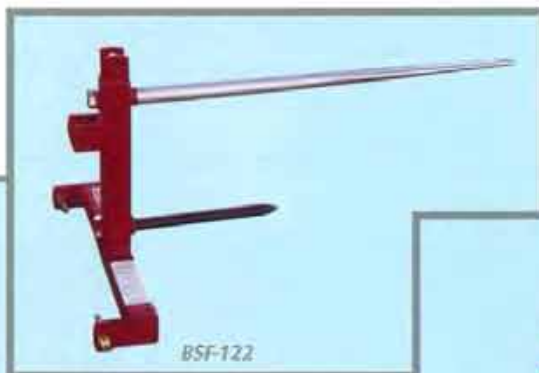

BSF-122



BSF-1523



BSFA-20

3-pt. *Bale Spears*

Work saver has the attachment that is right for your hay handling needs. Our 3-pt. mounted bale spears are designed, depending on model, to handle up to 3,000 lb. bales. The line features tapered "forged" spring steel spears designed for hard center bales allowing easier spear penetration of and withdrawal from bale(s). Each model is designed to mount to Category I/II hitches.

Model	Item No.	Description	Weight
BSF-1523	830235	Rated for round bales up to 1,800 lbs. Tapered main spear has useable length of 44" with welded balance spears.	57 lbs.
BSFA-20	830920	Adjustable height bale spear rated at 2,000 lbs. Uses bolt-in tapered main spear, useable length of 42" with welded balance spears.	78 lbs.
BSF-122	830935	Rated for round bales up to 2,200 lbs. Tapered main spear has useable length of 44", machined balance spike is 16" in length. Will fit Cat. I or II Quick Hitch.	72 lbs.
DBSF-30	830770	Double forged bale spear allows bale to be picked up and not lose its orientation. Uses two tapered spears with 44" useable length. Rated at 3,000 lbs.	78 lbs.
Replacement Spear & Spear Kit			
	831290	Replacement spear only, includes nut. Rated at 1,800 lbs.	22 lbs.
	830925	Bolt-on replacement forge spear kit. Includes spear, mounting plate (for 3" x 3" square tube) and hardware. Fits BSFA-20.	32 lbs.
	831273	Replacement spear only, includes nut. Rated at 2,200 lbs.	22 lbs.



*Replacement
Spear
#831290*

*Replacement
Spear
#831273*



3-pt. Bale Forks

In need of a tool to lift heavy bales? These bale forks can perform that task. Both models have patented, internally strengthened forks that feature triple-tapered fork points. Each fork also has a stabilizer spike.



WARNING: Do not exceed weight lifting capacity of your loader. Damage to equipment or personal injury could occur.



F-1511



F-3000

Model	Item No.	Description	Weight
F-1511	830030	3-pt. Bale Fork rated at 1,500 lbs. Forks are 55" in length, spaced 37-1/2" apart. Fits Cat. I/II as well as Cat. II Quick Hitch.	144 lbs.
F-3000	830101	3-pt. Bale Fork rated at 3,000 lbs. Forks are 55" in length, spaced 46-1/2" apart. Fits Cat. II as well as Cat. II Quick Hitch.	186 lbs.



HHU-2045

Bale Unroller & Handler

Ideal for unrolling large round bales for feeding. Conserves hay – by unrolling what cattle will eat in one hour. Easy operation from the tractor seat. Allows easy feeding relocation, which reduces manure buildup. The HHU-2045 fits Cat. I/II hitches, as well as Cat. I or II Quick Hitch.

Model	Item No.	Description	Weight
HHU-2045	831340	3-pt. Hay Handler/Unroller rated at 2,000 lbs. Designed for round bales either 4' or 5' in width up to 6' in diameter (requires a 2-1/2" x 8" cylinder and hoses, which are not included).	310 lbs.

Choose the **Worksaver** Way to Handle Your Hay

Work saver

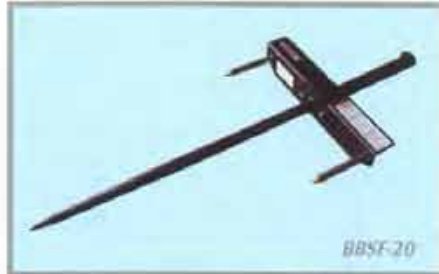

BBSF-20



CBSF-2028

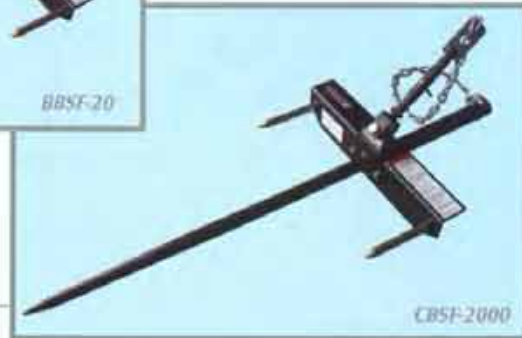

CBSF-2000

Bucket Bale Spears

Quickly convert your front loader bucket into a tool for handling large round bales. Each spear mounts on the bucket cutting edge with heavy angle iron for additional support and utilizes the bucket underside for leverage. The bolt-on or chain system is used to firmly lock the spear on the bucket. These units use tapered "forged" bolt-in steel spears.

 **WARNING:** Bale spears are to be inserted into bales. DO NOT use spears as forks.

Model	Item No.	Description	Weight
BBSF-20	830185	Bolt-on Bucket Bale Spear for round bales. Rated at 2,000 lbs. Bolt-in spear has useable length of 42". Requires drilling one 17/32" dia. hole in the bucket. Bolt-together design.	65 lbs.
CBSF-2000	830190	Clamp-on Bucket Bale Spear for round bales. Rated at 2,000 lbs. Uses chain & turnbuckle system. Bolt-in spear has useable length of 42". Bolt-together design.	76 lbs.
CBSF-2028	830930	Clamp-on Bucket Dual Bale Spear for round bales. Rated at 3,000 lbs. Uses chain & turnbuckle system. Bolt-in spears have useable length of 42". NOTE: Spears must be inserted into the bale.	101 lbs.

Optional Spears & Spear Kits

	831290	1,800 lb. tapered forged replacement spear with nut. Useable length of 44".	22 lbs.
	831273	2,200 lb. tapered forged replacement spear with nut. Useable length of 44".	22 lbs.
	830928	2,200 lb. tapered forged bolt-in replacement spear and bolt. Useable length of 42".	19 lbs.
	832217	2,200 lb. Bolt-in replacement spear kit. Includes tapered forged spear, sleeve, and bolt. Useable length of 42".	26 lbs.
	832215	2,200 lb. Bolt-in replacement spear kit with cast steel socket (patent pending). Includes tapered forged spear, bolt, and casting that welds to your 3" x 3" or larger square/rectangular frame. Useable length of 42".	29 lbs.



Spear kit #832215

 **WARNING:** Do not exceed weight lifting capacity of your loader. Damage to equipment or personal injury could occur.

Front Loader Bucket Tines

The T-2000 is capable of handling up to 2,000 lb. bales. The triple-tapered points easily slide under the bale. Upright masts & two stabilizer spikes keep bales in place during transport. **NOTE:** Not for use with pallets or spearing bales.



WARNING: Do not exceed loader or tractor operating lift capacity.



Model	Item No.	Description	Weight
T-2000	832280	Clamp-on Bucket Bale Forks. Rated at 2,000 lbs. Uses chain & turnbuckle system. Tubular forks are 3" x 2" x 50-3/4". Uprights, backstop & stabilizer spikes are included. Designed for handling round bales only. NOTE: Don't use as a spear or for pallets.	180 lbs.

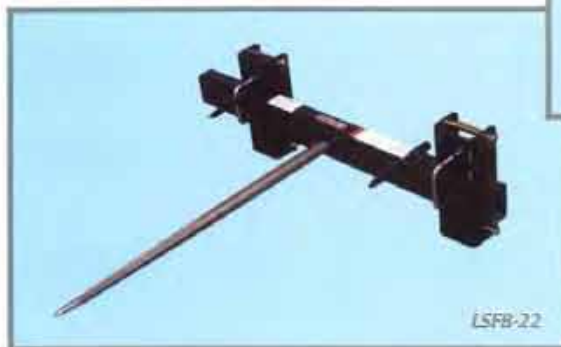

LS-Series Pin-on Type

The LS-Series front loader attachments are designed for pin-on type front loaders only. This economical attachment allows for easy handling of round bales.

Model	Item No.	Description	Weight
LSFB-22	832015	Designed for pin-type loaders only, and rated at 2,200 lbs. Bolt-in spear has useable length of 42". For use with round bales. Includes pin-on brackets.	150 lbs.
LSFB-28	832020	Designed for pin-type loaders only, and rated at 3,000 lbs. Bolt-in spears have useable length of 42". For use with round bales. Includes pin-on brackets.	165 lbs.



WARNING: Do not exceed weight lifting capacity of your loader. Damage to equipment or personal injury could occur.

Choose the **Worksaver** Way to Handle Your Hay

Work saver



RBSF-Series Loader Attachments

Handling large or mid-size rectangular bales is easier using one of our models to perform the job. All models feature tapered "forged" spring steel spears. Optional pin-on brackets or interfacing brackets for most popular quick-attach front loaders are available with loader arm distance of 55" or less. These attachments are convertible for use on a 3-pt. hitch with the addition of the optional bolt-on ear assembly (not Quick Hitch adaptable).

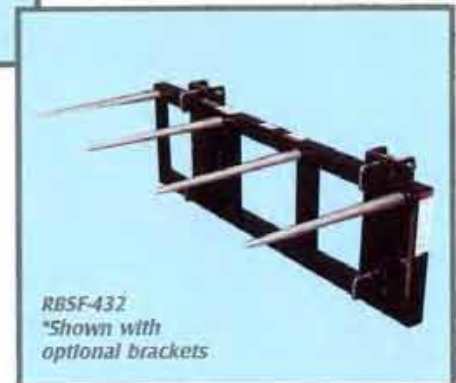
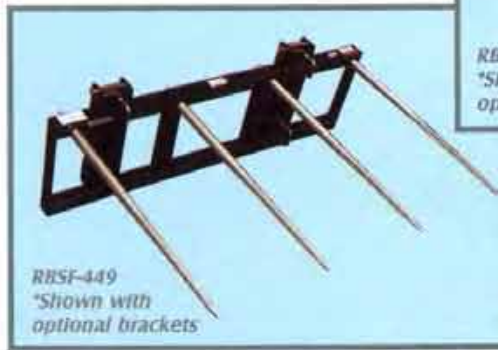
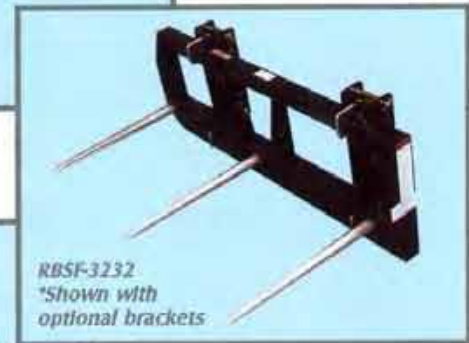
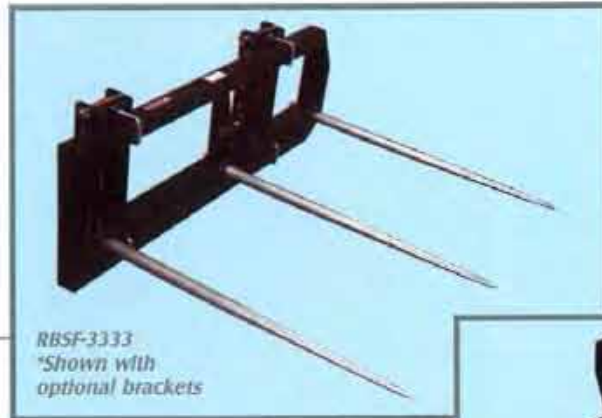

Model	Item No.	Description	Weight
RBSF-3232	830690	Loader Bale Spear, rated at 3,000 lbs. for handling single mid-size square bales. Triple spears have useable length of 26", spaced 26-1/2" apart. Use of optional uprights 830693 is required to handle two bales.	246 lbs.
RBSF-3333	830455	Loader Bale Spear, rated at 4,000 lbs. for handling single mid-size square bales. Triple spears have useable length of 44", spaced 26-1/2" apart. Use of optional uprights 830693 is required to handle two bales.	279 lbs.
RBSF-449	831495	Loader Bale Spear to handle one rectangular bale. Frame is 72" wide with 4 tapered spears with useable length of 44". Spaced 22" apart. Optional uprights required to handle two bales.	275 lbs.
RBSF-432	831499	Loader Bale Spear to handle one rectangular bale. Frame is 72" wide with 4 tapered spears with useable length of 26". Spaced 22" apart. Optional uprights required to handle two bales.	242 lbs.
Optional Bolt-on Uprights & Bolt-on Ear Assembly			
	830693	Optional bolt-on uprights for RBSF-3232/3333 for handling two bales.	69 lbs.
	831491	Optional bolt-on uprights for RBSF-449/432 for handling two bales.	88 lbs.
	831815	Optional bolt-on ear assembly allows RBSF-series to be used on Cat. II 3-pt. hitch.	19 lbs.



WARNING: Do not exceed weight lifting capacity of your loader. Damage to equipment or personal injury could occur.

UBSF-Series Loader Attachments

The UBSF-Series is designed for use on pin-type front loaders or most popular quick-attach front loader systems using our optional interfacing brackets. These attachments are convertible for use on a 3-pt. hitch with the addition of the optional bolt-on ear assembly (not Quick Hitch adaptable).



Model	Item No.	Description	Weight
UBSF-2018	831775	Loader Bale Spear, rated at 1,800 lbs. Tapered spear has useable length of 44". Single machined balance spike. Optional interfacing brackets for most quick-attach systems are available.	197 lbs.
UBSF-2022	831778	Loader Bale Spear, rated at 2,200 lbs. Tapered spear has useable length of 44". Single machined balance spike. Optional interfacing brackets for most quick-attach systems are available.	204 lbs.
UBSF-2030	831772	Loader Bale Spear, rated at 3,000 lbs. Dual tapered spears have useable length of 44". Optional interfacing brackets for most quick-attach systems are available.	246 lbs.
Optional Bolt-on "Ear" Assembly, Spears & Spear Kit			
	831815	Optional bolt-on "ear" assembly allows UBSF attachments to be used on a Cat. II 3-pt. hitch.	17 lbs.
	831273	Replacement spear only, includes nut. Rated at 2,200 lbs.	
	831190	Boxed Forged replacement spear kit. Complete with nut, sleeve packaged in a carton. Rated at 2,200 lbs.	26 lbs.



Spear Kit
#831190



WARNING: Do not exceed weight lifting capacity of your loader. Damage to equipment or personal injury could occur.



Rectangular Bale Handler

This unit is designed to handle and stack large rectangular bales. Features include heavy-duty UHMW-polyethylene bushings for smooth operation and long service life. Five 26" long "forged" spears are placed along the bottom with six 18" long spears supplied for the uprights providing additional support. Each side features five hooks that are moveable to the most convenient location for handling your bales.

Model	Item No.	Description	Weight
RBH-4000	831460	Large Rectangular Bale Handler, rated at 4,000 lbs. Designed for tractor front loaders. Unit will handle either two 4' x 4' x 8' or three 3' x 3' x 8' rectangular bales. Includes hydraulic cylinder. Optional pin-on brackets or interfacing brackets for most popular quick-attach front loaders are available with loader arm distance of 55" or less.	881 lbs.

UBH-Series for Wrapped (or Dry) Round Bales

The "Bale Hugger" & "Bale Hand" will gently handle large round wrapped or unwrapped bales with weight up to 2,200 lbs. Both provide smooth curved clamping arms to prevent wrapped bale puncture. Each unit fits most double-cylinder front loaders with load arm distance of 54" or less. Optional pin-on brackets or interfacing brackets for most popular quick-attach front loaders are available with loader arm distance of 55" or less.



Model	Item No.	Description	Weight
UBH-2000	832850	"Bale Hugger" rated at 2,000 lbs. Designed to handle round bales from 4' to 6'. Features one stationary arm, one opening arm. Hydraulic cylinder included.	435 lbs.
UBH-2072	832940	"Bale Hand" rated at 2,200 lbs. Designed to handle round bales from 4' to 6'. Both arms open to clamp bale. Hydraulic cylinder included.	529 lbs.

Skid Steer Bale Hand for Wrapped (or Dry) Round Bales

The Skid Steer "Bale Hand" gently handles large round wrapped or unwrapped bales. Features smooth curved arms to prevent wrapped bale puncture when clamping. Fits skid steer and front loaders with the "Universal" quick-attach system.

Model	Item No.	Description	Weight
SSBH-2072	832965	Skid Steer "Bale Hand" designed to handle 4' to 6' round bales. Both arms open to clamp bale. Hydraulic cylinder included.	470 lbs.



WARNING: Do not exceed weight lifting capacity of your loader. Damage to equipment or personal injury could occur.

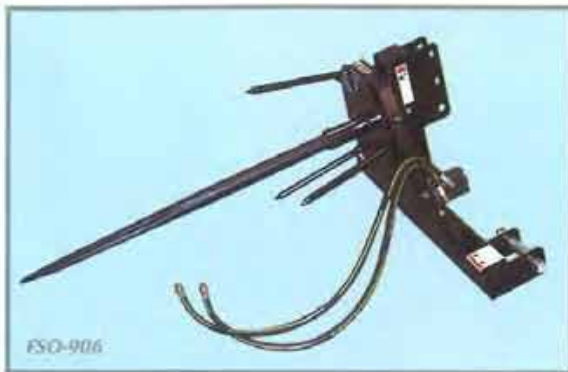

FSO-906

RW Spin Off

Designed as an efficient hay management tool for moving and feeding round bales, the RW Spin Off hydraulically rotates the bale, unwinding the hay into a windrow. Rotates in both directions for easy feeding and allow the operator to unroll what the cattle will clean up in one hour, eliminating wasted hay. Also, by changing the feeding location each day the operator can eliminate manure buildup. Available in three models and designed to fit Category II or Category III 3-pt hitches (FSO-906), front loaders (FLSO-907) and skid steers (SSSO-908). All models are hydraulically driven for better operator control, provide easy operation from the cab of tractors or skid steers and feature a forged tapered spear for easier bale penetration. All have useable spear length of 53".



FLSO-907

SSSO-908



Model	Item No.	Description	Weight
FSO-906	831000	3-pt. hydraulically driven bale spin off for Cat. II/III size tractors. Requires 8-10 gpm of hydraulic flow. Tapered forged spear.	250 lbs.
FLSO-907	831020	Front loader mounted hydraulically driven bale spin off for Cat. II/III size tractors. Requires 8-10 gpm of hydraulic flow. Tapered forged spear. Optional pin-on brackets or interfacing brackets for most popular quick-attach front loaders are available with loader arm distance of 55" or less.	288 lbs.
SSSO-908	831030	Skid steer mounted hydraulically driven bale spin off. Requires 8-10 gpm of hydraulic flow. Designed to interface with "Universal" skid steer quick attach system.	325 lbs.

Choose the **Worksaver** Way to Handle Your Hay



WARNING: Do not exceed weight lifting capacity of your loader. Damage to equipment or personal injury could occur.

Worksaver



Quality attachments that are changing it all!

Integrated-Frame Design for John Deere Loaders

Integrated-Frame Design for John Deere loaders features all welded frame that incorporates interfacing quick-attach brackets for John Deere Loaders. All models utilize durable bolt-in forged spears.



JDBS-623

Integrated-Frame Design for John Deere loader models: 300, 300CX, 400X, 410, 420, 430, 440, 460, 520, 521, 540, and 541.

Model	Item No.	Description	Weight
JDBS-412	832290	Single bolt-in forged spear with useable length of 42". Rated at 2,200 lbs. Two balance spikes, 1"x 8-1/2" useable.	121 lbs.
JDBS-423	832320	Dual bolt-in forged spears spaced 26-1/2" apart, with useable length of 42". Rated at 3,000 lbs.	156 lbs.
JDBS-433	832330	Triple bolt-in forged spears spaced 26-1/2" apart, with useable length of 26". Rated at 3,000 lbs.	164 lbs.
JDBS-434	832335	Triple bolt-in forged spears spaced 26-1/2" apart, with useable length of 42". Rated at 4,000 lbs.	191 lbs.
Optional Bolt-on Upright Kit			
	831095	Optional bolt-on upright kit for handling two bales. Fits models JDBS-433 & -434.	32 lbs.

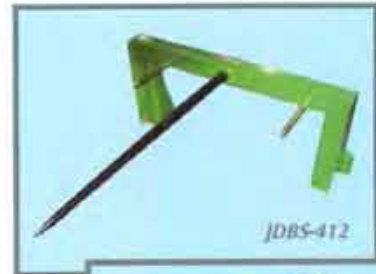

JDBS-412



JDBS-434

Integrated-Frame Design for John Deere loader models: 620, 640, 720, 721, 725, 726, 740, and 741.

Model	Item No.	Description	Weight
JDBS-612	832340	Single bolt-in forged spear with useable length of 42". Rated at 2,200 lbs. Two balance spikes, 1"x 8-1/2" useable.	176 lbs.
JDBS-623	832350	Dual bolt-in forged spears spaced 30" apart, with useable length of 42". Rated at 3,000 lbs.	196 lbs.
JDBS-633	832355	Triple bolt-in forged spears spaced 28-1/2" apart, with useable length of 26". Rated at 3,000 lbs.	204 lbs.
JDBS-634	832630	Triple bolt-in forged spears spaced 28-1/2" apart, with useable length of 42". Rated at 4,000 lbs.	231 lbs.
Optional Bolt-on Upright Kit			
	831095	Optional bolt-on upright kit for handling two bales. Fits models JDBS-633 & -634.	32 lbs.



JDBS-612



JDBS-634
with optional
uprights



WARNING: Do not exceed weight lifting capacity of your loader. Damage to equipment or personal injury could occur.

Professionals demand quality.



SSRB-340



SSB-2200



SSRB-330 with optional uprights

Skid Steer & Front Loader Bale Handling Attachments

These patent pending attachments are designed for front loaders and skid steers using the industry standard "universal quick-attach" system. Unique step through design provides easy access to the skid steer. Bale spears are offered to handle large round bales as well as mid-size and large rectangular bales. Optional uprights allow handling of two rectangular bales at a time. All units utilize bolt-in "forged" spring steel tines for easy spear penetration of the bale.



SSB-3000

Model	Item No.	Description	Weight
SSB-2200	831060	Skid Steer Single Bale Spear. Forged Tapered bolt-in spear with useable length of 42". Rated at 2,200 lbs.	129 lbs.
SSB-3000	831070	Skid Steer Dual Bale Spear. Forged Tapered bolt-in spears with useable length of 42". Rated at 3,000 lbs.	146 lbs.
SSRB-340	831095	Skid Steer Triple Bale Spear. Forged Tapered bolt-in spears spaced 26-1/2" apart, with useable length of 42". For handling single or double (with optional uprights # 831095) large-size square bales. Rated at 4,000 lbs.	190 lbs.
SSRB-330	831080	Skid Steer Triple Bale Spear. Forged tapered bolt-in spears spaced 26-1/2" apart, with useable length of 26". For handling single or double (with optional uprights # 831095) mid-size square bales. Rated at 3,000 lbs.	165 lbs.
Optional Bolt-on Uprights			
	831095	Optional bolt-on uprights for SSRB-330 & SSRB-340 allow handling two bales at once.	32 lbs.

Choose the **Worksaver** Way to Handle Your Hay



WARNING: Do not exceed weight lifting capacity of your loader. Damage to equipment or personal injury could occur.

Global-Style Integrated Frame Bale Spears

Features an all welded frame design that incorporates the Euro Style quick attach brackets. Designed to fit front loaders with the widely used Global/Euro – Implement hook standard. Features cast steel weld-on sockets (patent pending) and bolt-in forged spears.



GLB-340



GLB-3000



GLB-2200



GLB-330
with optional
uprights

Model	Item No.	Description	Weight
GLB-2200	832205	Single bolt-in forged spear with useable length of 42". Two balance spikes, 1" x 8-1/2" useable. For round bales. Rated at 2,200 lbs.	114 lbs.
GLB-3000	832220	Dual bolt-in forged spears spaced 30" apart, with useable length of 42". For round bales. Rated at 3,000 lbs.	128 lbs.
GLB-330	832245	Triple bolt-in forged spears spaced 28-1/2" apart, with useable length of 26". For handling single or double (with optional uprights #831095) mid-size square bales. Rated at 3,000 lbs.	147 lbs.
GLB-340	832240	Triple bolt-in forged spears spaced 28-1/2" apart, with useable length of 42". For handling single or double (with optional uprights #831095) large-size square bales. Rated at 4,000 lbs.	174 lbs.
Replacement Spear & Spear Kits			
	830928	Bolt-in replacement spear only. Rated at 2,200 lbs.	22 lbs.
	832215	2,200 lb. Bolt-in replacement spear kit with cast steel socket (patent pending). Includes tapered forged spear, bolt, and casting that welds to your 3" x 3" or larger square/rectangular frame. Useable length of 42".	29 lbs.
	831095	Optional uprights for GLB-330 & -340.	32 lbs.



WARNING: Do not exceed weight lifting capacity of your loader. Damage to equipment or personal injury could occur.



Caution — Be sure stabilizer spike is in place when handling large round hay bales with fork-type equipment.

Caution — A heavy load can cause your tractor to tip over. When moving heavy loads, keep the load as close to the ground as possible, go slowly around turns, and be sure the front or rear of tractor is properly counterbalanced with weights.

Caution — Operators must read & understand operator's manual, particularly the safety warnings and instructions.

The operator is responsible for safety of themselves and others when operating equipment.

WORKSAVER, INC. has a corporate policy of continuous product improvement and development; therefore, specifications are subject to change without any advance notice. WORKSAVER, INC. is not responsible for differences between specifications or illustrations contained in this publication and the actual equipment.



**Implements
Designed
for Your
Lifestyle.**



Worksaver, Inc.

P.O. Box 100, Litchfield, IL 62056-0100

Phone: 217-324-5973 • Fax: 217-324-3356

E-mail: sales@worksaver.com

Web: www.worksaver.com

Distributed by:

Worksaver.

**Implements
Designed for
Your
Lifestyle**



WORKSAVER®



Designed as an efficient hay management tool for moving and feeding round bales. The Spin Off hydraulically rotates the bale, unwinding the hay in to a windrow.





- Eliminate wasted hay; only unroll what cattle will clean up in one hour.
- Almost no manure buildup; by feeding in a different location each day.
- Easy operation from the cab of the tractor or Skid Steer.
- Models for 3-pt, Front Loaders & Skid Steers.
- Hydraulically driven for better operator control.
- Rotates in both directions for easy feeding.
- Cushion valve in the motor provides protection for hydraulic components.
- Forged tapered spear for easier spear penetration.

SPECIFICATIONS

Model	FSO 906	FLSO-907	SSSO-908
Item No.	831000	831020	831030
Frame Size	4" x 4" Sq. Tubing	3" and 4" Sq. Tubing	3" and 4" Sq. Tubing
Spear	Tapered Forged	Tapered Forged	Tapered Forged
Attaching Method	3-pt Cat. II/III **	Front Loader Pin-on *	Skid Steer "universal"
Drive			
Chain Type	#50 Roller Chain	#50 Roller Chain	#50 Roller Chain
Sprocket Ratio	3.75:1	3.75:1	3.75:1
Hydraulics			
GPM – Requirements	8-10 GPM	8-10 GPM	8-10 GPM
PSI – Requirements	Min. 1500 psi	Min 1500 psi	Min 1500 psi
Hoses	Supplied (2) less ends	Less Hoses	Supplied (2) less ends
Cushion Valve			
Factory Setting – Relief	1750 psi	1750 psi	1750 psi
Dimensions			
Height	26-3/4"	23-1/4"	23-1/4"
Width	44-3/4"	60-1/2"	45-1/4"
Length w/ Spear	64-3/4"	64-3/4"	64-34"
Weight	250 lbs	370 lbs	325 lbs

* Optional interfacing brackets for most loader quick attach systems are available

** Optional pin & bushing kit available to allow use on Cat. I 3-pt hitch



READ AND UNDERSTAND OPERATOR'S MANUAL BEFORE OPERATION.

Worksaver Inc. has a corporate policy of continuous product improvement and development; therefore, specifications are subject to change without any advance notice. Worksaver Inc. is not responsible for differences between specifications or illustrations contained in this publication and the actual equipment.



Worksaver, Inc.

P.O. Box 100, Litchfield, IL 62056-0100

Phone: 217-324-5973 • Fax: 217-324-3356

E-mail: sales@worksaver.com

Web: www.worksaver.com

Information Provided By:

