

Kelley[®]

*Series
800 & 600*

Loaders



A Versatile Power Packed Loader

Series 800 Loader



KELLEY Series 800 Extra Heavy Duty Loader on a 4-Wheel Drive Tractor.

KELLEY LOADERS are adaptable to a wide range of American and Foreign make of Tractors.

KELLEY 800 LOADER: SPECIFICATIONS

(Conforms to IEMC standards where applicable)

SIZE	PSI	Break-A-Way (PAYLOAD IN BUCKET)	SIZE	PSI	Break-A-Way (PAYLOAD IN BUCKET)	Cylinders
2" DA	2000	3063 lbs.	2½" DA	1500	4575 lbs.	"Chrome Plated"
	2500	3572 lbs.		2000	5500 lbs.	Front Pumps & Rear Pumps Available
						Operator's Control Valve
						Cross
						Base Loader Weight
						Less Bucket
						1000 lbs. avg.

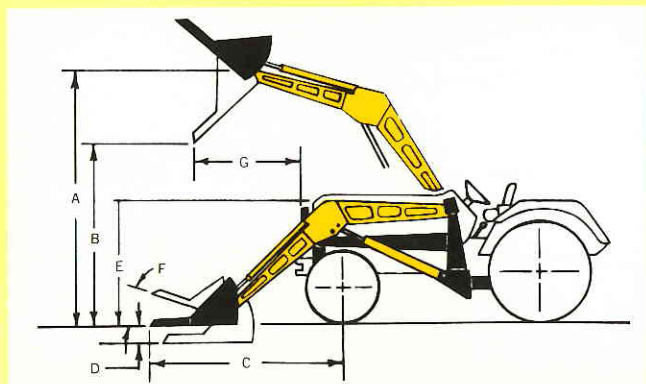

A. Maximum Lift Height	118"
B. Clearance Fork Dumped	94"
C. Reach — Fork on Ground	78"
D. Digging Depth	5"
E. Overall Height — Carry Position	61"
F. Fork Roll Back (Hydraulic Bucket Only)	13"
G. Reach — Maximum Height	44"

NOTE: Measurements and performance data shown will vary slightly with different tractor models, tire sizes, & variations in hydraulic systems involved.

Kelley®

Series 600



**Rugged,
Versatile and
Powerful
by Design and
Construction.**

**A Modest
Investment
for Maximum
Service.**



KELLEY 600 LOADER: SPECIFICATIONS

BREAK-A-WAY POWER IN BUCKET (PAYLOAD)

P. S. I.	Cylinder Size 1 3/4"	P. S. I.	Cylinder Size 2 1/2"	Cylinders	Chrome Plated
2000	3,000 lbs.	1000	3,050 lbs.	Operator's Control Valve	Cross
2250	3,375 lbs.	1250	3,825 lbs.	Base Loader Weight —	
2500	3,750 lbs.	1500	4,575 lbs.	Less Bucket	535 lbs. avg.
2750	4,125 lbs.				

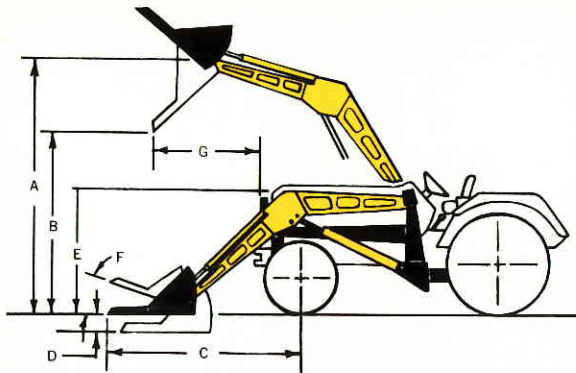

A. Maximum Lift Height	122"
B. Clearance Fork Dumped	96"
C. Reach — Fork on Ground	70"
D. Digging Depth	5"
E. Overall Height — Carry Position	60"
F. Fork Roll Back (Hydraulic Bucket Only)	8"
G. Reach — Maximum Height	28"

NOTE: Measurements and performance data shown will vary slightly with different tractor models, tire sizes and various hydraulic systems involved.

— C. C. KELLEY and SON

Kelley

DL2000

QUICK

DETATCHABLE

LOADER



- Commercial
- Farm
- Estate

For 20 to 45
horsepower
tractors



A Versatile Power-Packed Loader

DL2000 Loader for your 20 to 45 horsepower tractor!



Quick-Detachable Design

Many compatible loader mountings for most compact utility tractors. Heavy-duty bucket attachments with high carbon cutting edges - available in 54" - 60" widths. Other optional attachments include: High capacity 60" Snow and Litter Bucket, 56" Manure Bucket and 48" Pallate Fork attachment. Bucket Level Indicator standard.



Detach or Attach Quickly

The Kelley DL2000 can be quickly Detached to free your tractor for other jobs or Attached in just minutes to your tractor using the convenient "handled" mainframe, lift cylinder and bucket pivot pins.

- Hydraulic Oil Couplers conveniently located at Control Valve Works Ports.
- Parking Stands support dismounted loader. Drive tractor forward into the parked loader.
- Couple the cylinder's hydraulic hoses to the valve's oil couplers - to activate loader.
- Rotate and pivot loader assembly onto the side frame supports by hydraulic activation of bucket cylinders - Install handled pins for strong and solid mounting.
- Activate lift cylinders into their pivot support and secure with handled pins.
- Hydraulically raise loader. Remove Parking Stands and relocate to stored position on loader side frames.



Wrap Around Rugged Mounting

The DL2000 has heavy-duty front to rear axle mountings which eliminate excessive shock load on the mid-section of smaller tractors. Wrap-around side frame and quick release front bumper grill provides maximum mounting strength and further protects tractor. Design allows hood of tractor to tilt forward for easy engine access and servicing. Loader mainframe arms are reinforced to provide optimum loader capacity and durability - major pivot pins are locked from rotating and zerked for lubrication. Two-inch "Double-action" hydraulic bucket cylinders and lift cylinders provide Powerful Performance. Constructed with high quality chrome plated shafts and dependable, long life internal parts.

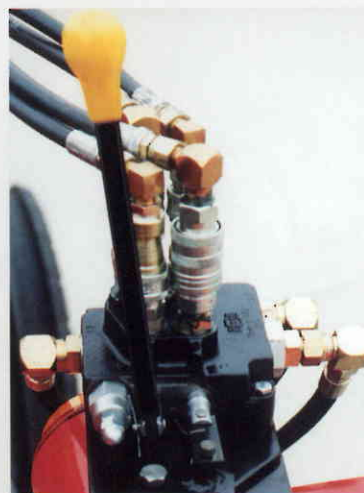

Single Lever Control

Single lever valve control for ease of operations on the DL2000 is standard. Simple to hydraulically maneuver bucket back into working position - Raise or lower lift cylinders with float position spool - Dump or roll-back bucket cylinders with the convenient Single Lever Control - permits for a powerful and versatile loader performance under varying ground conditions and contours. "Power Beyond" valve capacity permits versatile and safe hydraulic operations for tractor and for other compatible accessory equipment.

Example: Backhoe, Logsplitter.

DL2000 Loader Performance Specifications

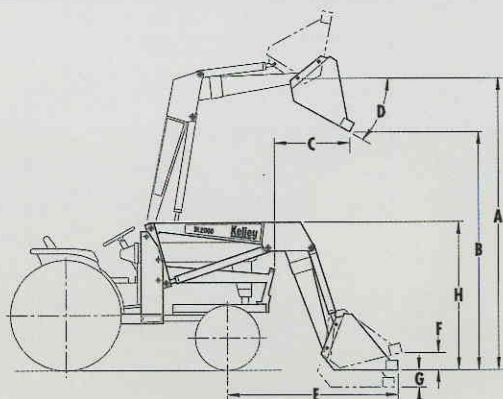

A. Maximum Lift Height to Pin.....	8' 9"
B. Clearance with Bucket Dumped.....	7' 3"
C. Reach at maximum Height.....	22"
D. Maximum Dump Angle.....	42°
E. Reach with Bucket on Ground.....	4' 9"
F. Bucket Roll Back.....	5"
G. Digging Depth.....	6"
H. Overall Height in Carrying Position.....	4' 4"
Lift Capacity to Full Height.....	900 lbs.
Breakout Force at Bucket Tip.....	2000 lbs.
Rated Pressure.....	2000 PSI

Note: Counterweight or ballast must be added to the rear of the tractor for stability and safe loader operation. Shipped partially assembled - Palletted.

Loader Wgt: 1000 lb. avg. (with 60" Material Bucket, Valve Kit, and Mounting Kit)

SOLD BY:



Kelley

Kelley Manufacturing Corporation

61501 BREMEN HIGHWAY • MISHAWAKA, IN • 46544-9724

Phone: (219) 255-4746 Fax: (219) 255-6817

E-mail: sales@kelleymanufacturing.com

Web URL: www.kelleymanufacturing.com

Kelley

DL3000 LOADER

For 45 to 95 Horsepower Tractors

- ★ QUICK-DETACHABLE
- ★ VERSATILE
- ★ POWER PACKED

See It in Action!

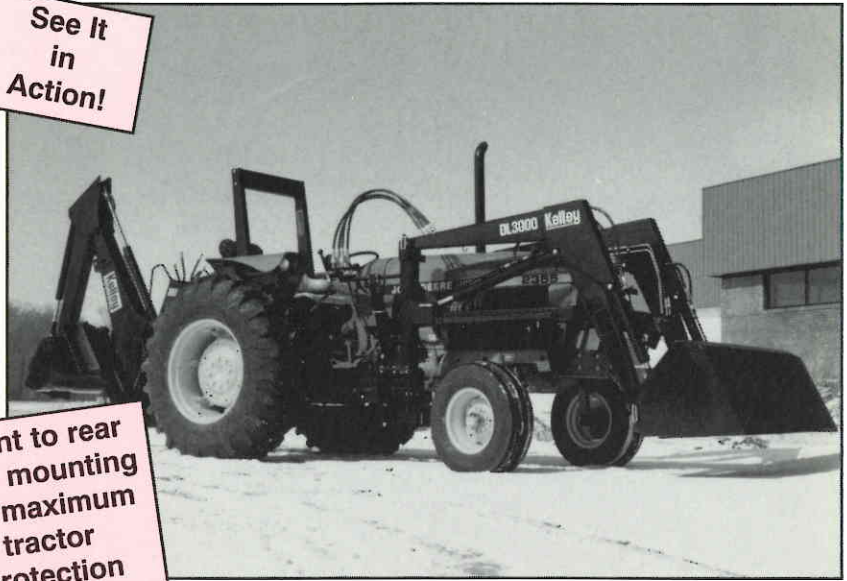

Front to rear axle mounting for maximum tractor protection



SPECIFICATIONS

A	Maximum Lift Height	132"
B	Clearance Dumped	120"
C	Reach - Bucket on Ground	62"
D	Digging Depth	6"
E	Overall Height Carry Position	64"
F	Roll Back - Bucket	6"
G	Reach - Maximum	24"
H	Bucket Tilt at 132" Height	25°
H	Bucket Tilt at 120" Height	35°

Note: Measurements and performance data shown will vary slightly with different tractor models, tire sizes, and variations in hydraulic systems involved.

PERFORMANCE FEATURES

Responsive Operation with 2 1/2" Double-Acting Lift Cylinders and 2 1/2" Double-Acting Bucket Cylinders.

Break-A-Way	4,663 lbs.
Full Height	2,532 lbs.
6' Height	3,348 lbs.

Note: Based on 2250 PSI Pressure Relief Cross Single Lever Control Valve. All weights are electronically scaled.

64" Material Bucket	13.75 cu ft.
72" Material Bucket	15.5 cu ft.
84" Material Bucket	17.25 cu ft.

64" and 72" Manure Buckets Available
Bale Carriers & Pallet Fork Attachments

Wrap-Around Side Frames and Front Grill Protection.
Loader Main Frame Reinforced for Optimum Loader Capacity and Durability.

Convenient Handled Bucket Pins for Quick Release of Bucket or Other Attachment.

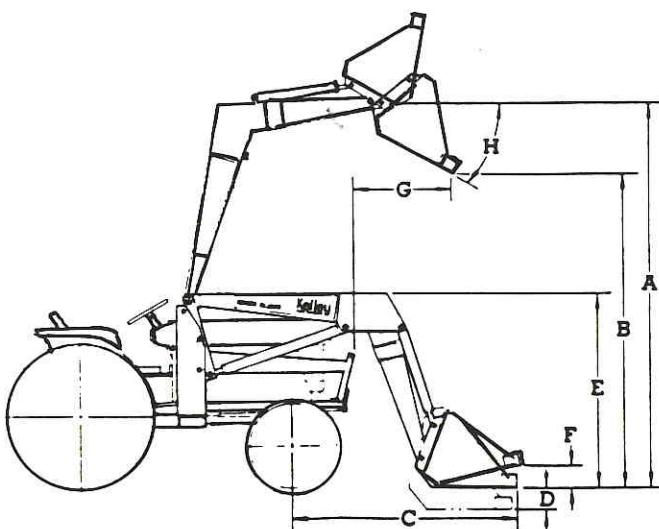

Approximate Shipping Weight 1500 lbs.
(with 72" Material Bucket, Valve Kit, and Mounting Kit.)

Kelley

Kelley Manufacturing Corporation
61501 Bremen Highway
Mishawaka, IN 46544-9724
(219) 255-4746 • Fax: (219) 255-6817

SOLD BY:

